

J. FLATHER.
ENGINE LATHE.

No. 398,601.

Patented Feb. 26, 1889.

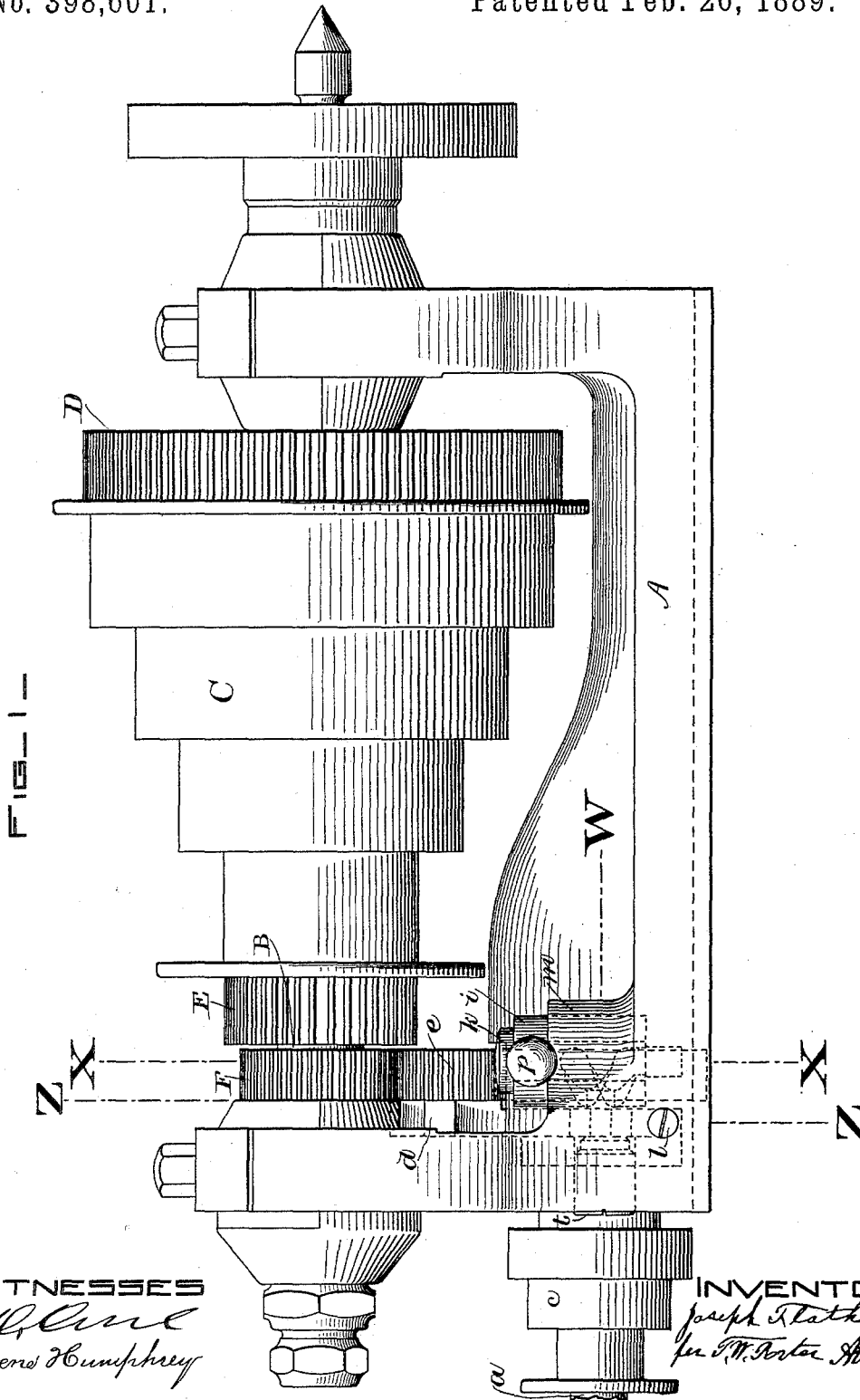

FIG. 1—

WITNESSES
Arthur
Eugene Humphrey

INVENTOR
Joseph Flather
per J. W. Boston Atty.

(No Model.)

2 Sheets—Sheet 2.

J. FLATHER.

ENGINE LATHE.

No. 398,601.

Patented Feb. 26, 1889.

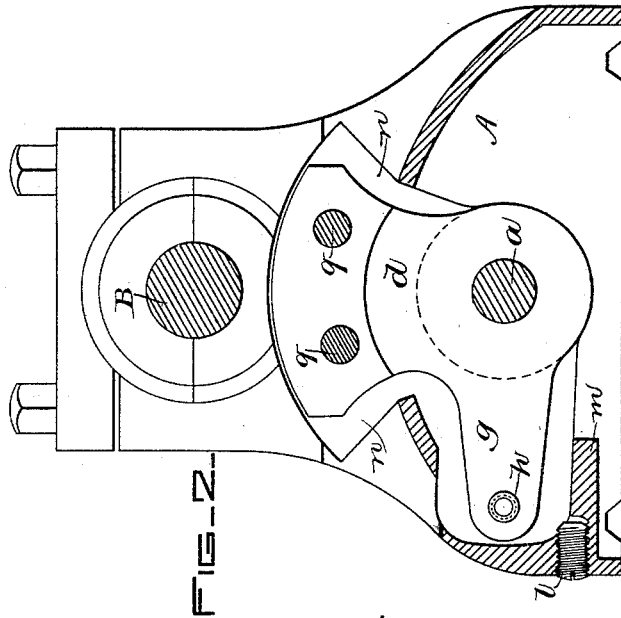
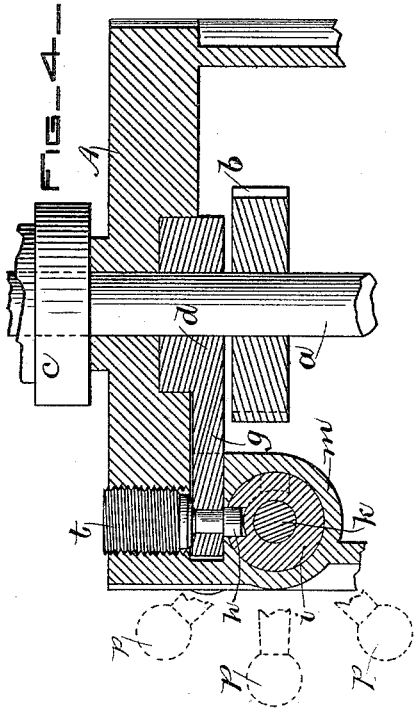
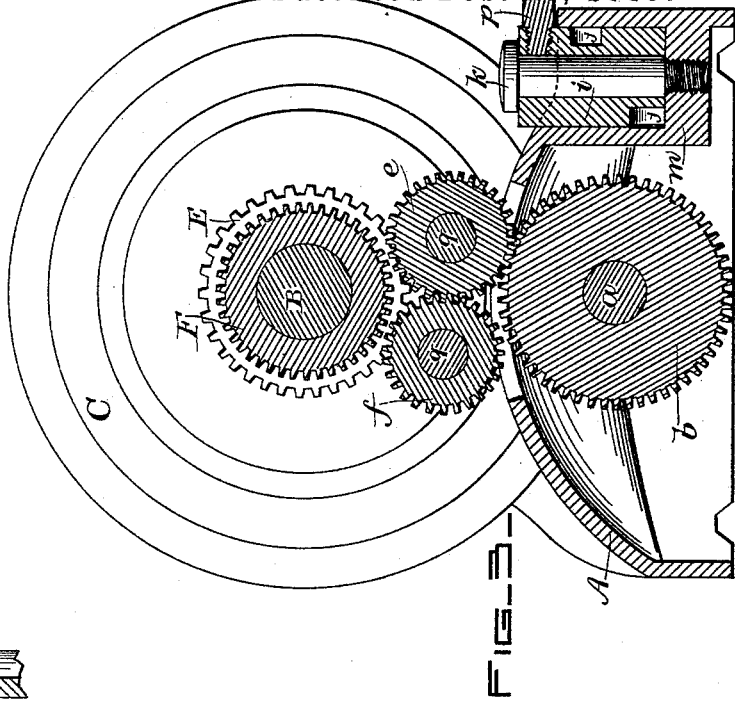
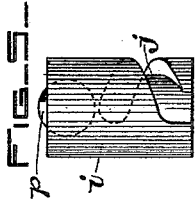

WITNESSES

A. G. Orne
Eugene Humphrey

INVENTOR
Joseph Flather
Per C. W. Porter Atty

UNITED STATES PATENT OFFICE.

JOSEPH FLATHER, OF NASHUA, NEW HAMPSHIRE.

ENGINE-LATHE.

SPECIFICATION forming part of Letters Patent No. 398,601, dated February 26, 1889.

Application filed June 21, 1888. Serial No. 277,757. (No model.)

To all whom it may concern:

Be it known that I, JOSEPH FLATHER, of Nashua, in the county of Hillsborough and State of New Hampshire, have invented a new and useful Improvement in Engine-Lathes, which will, in connection with the accompanying drawings, be hereinafter fully described, and specifically defined in the appended claims.

In said drawings, Figure 1 is a front side elevation of the head-stock of an engine-lathe embodying my invention. Fig. 2 is a vertical transverse section taken on line Z Z, Fig. 1, and viewed as from the right therein. Fig. 3 is a section similar to Fig. 2, but taken on line X X, Fig. 1, and viewed as from the left therein. Fig. 4 is a detached horizontal section taken on line W, Fig. 1, the view being from above that line. Fig. 5 shows the cam in side elevation.

This invention relates to that class of lathes known to mechanics and the trade as "engine-lathes," which are provided with a reversible automatic feed mechanism; and my invention relates to the means for reversing the feed mechanism; and it consists in features of novelty which will be herein pointed out, and specified in the claims.

Referring again to the drawings, A represents the head-stock; B, the spindle journaled in suitable bearings secured in stock A; C, the cone-pulley mounted on arbor B; D, the larger gear secured upon B, and E the smaller gear secured to cone C, said several parts being old in their construction, arrangement, and mode of operation, the gears being a part of what is known as the "back-gearing," the coacting gears and their adjustable or rocking shaft not being shown, as my invention has no direct relation therewith, and would perform the same function whether such back-gearing was employed or not. Between the back journal-box of spindle B and gear E is arranged the feed-gear F, rigidly secured upon said spindle in the usual manner. Below spindle B is arranged the feed-spindle *a*, journaled in stock A and carrying the gear *b*, rigidly secured upon it directly beneath said feed-gear F, secured on spindle B. A gear-carrier, *d*, is mounted upon spindle *a* between gear *b* and the rear upright

of stock A, and upon said carrier are mounted the intermediate gears, *e f*, pivoted upon their respective studs *g*, secured in the upper part of said carrier. Said gears *e f* are always enmeshed each with the other, and gear *e* is always enmeshed with gear *b* on spindle *a*, as shown.

For the purpose of rocking carrier *d*, (as will be explained,) an arm, *g*, thereof extends forward, as shown in Figs. 2 and 4, and by raising said arm, gear *e* is enmeshed with gear F, when gears F *e b* become a three-gear train, gears F and *b* of course revolving in the same direction as do their respective spindles on which they are secured; and when said arm is fully depressed gear *e* is released from gear F, and gears *f F* are enmeshed, when gears F, *f*, *e*, and *b* become a four-gear train, and spindles B *a* revolve in opposite directions. When said lever *g* is arranged midway between its highest and lowest limit, then both gears *e* and *f* are liberated from gear F, and they, as also gear *b* and its spindle, are at rest or non-rotative. These several gears, their movements, and described mode of operation are all old in this art; but to actuate and control said rocking carrier and its gears I have invented the following means:

A cam, *i*, having a spiral cam-groove, *j*, is pivoted to the base of stock A by the self-locking screw *k*, a hollow boss, *m*, being preferably formed integral with the stock, in which to seat said cam, as shown. A stud, *h*, secured in arm *g*, Figs. 2 and 4, engages in groove *j* in the cam, and by rotating the latter by its lever *p* said arm is vertically adjusted as desired. Said cam-groove is opened to the lower end or face of the cam, as shown in Fig. 5, in order to insert the stud in the groove after the lever and stud are in place in the stock. Said groove is carried up just far enough to allow the desired upward movement of arm *g* to properly engage gear *e* with gear F, while to control the downward movement of said lever a conical-pointed screw, *l*, is threaded in stock A to serve as an adjustable stop for the lever.

In Fig. 4 the several positions of lever *p* when adjusting the cam are shown, to wit: When turned to the right, arm *g* is depressed and gear *f* enmeshed with gear F. When turned to the left, the arm is raised and gear *e* is

enmeshed with gear F, and when intermediate, both gears *e* and *f* are freed from gear F, as above specified. In order to form the slot or space in the wall of A for arm *g* as small as practicable, the stud *h* is inserted and secured in the arm after the latter is in place, the stud being entered through the opening in boss *m* before the cam is seated therein; and to obtain access to the diminished end of the stud to rivet it in the arm, as shown, I form a threaded opening for plug-screw *t* in the end wall of A, opposite to said stud, said screw, when inserted in said opening, serving as an adjustable bearing to prevent side movement or thrust of said arm, and as a means of locking said arm, if necessary.

It will be obvious that the method of engaging said arm *g* and the cam may be varied without departing from the spirit of my invention, for the side or end of the arm may be formed with teeth like those in a tangent-wheel, while the cam may be cut as an endless screw, thus constituting the conventional "worm-gear;" but all such connections are well-known equivalents of the groove and pin shown and described.

Upon the outside of stock A the cone-pulley *c* is secured to spindle *a*, a belt from said pulley engaging a corresponding pulley on the "feed-rod" below in a well-known manner;

and if the lathe be what is termed a "screw-cutting" lathe then removable gears are secured on said spindle, outside pulley *c*, to engage an intermediate gear, by which motion is positively transmitted to the screw-cutting feed-rod in an equally well-known manner.

I claim as my invention—

1. In an engine-lathe, the combination, with gear-carrier *d*, having arm *g*, provided with the side stud, *h*, of cam *i*, mounted on vertical axis *k* and formed with spiral groove *d*, interlocked with said stud and provided with lever *p*, all substantially as specified.

2. The combination of gear-carrier *d*, cam *i*, and the adjustable arm-supporting screw *t*, arranged at the side of said arm, substantially as specified.

3. The combination of spindle B, feed-gear F, secured thereon, feed-spindle *a*, with its fixed gear *b*, gear-carrier *d*, having arm *g*, with its stud *h*, gears *e f*, mounted on said carrier, and cam *i*, mounted on its axis *k* and formed with groove *j*, interlocked with said stud *h* and arranged to actuate said carrier, all substantially as specified.

JOSEPH FLATHER.

Witnesses:

T. W. PORTER,
EUGENE HUMPHREY.